



Mobile Rolling Spring Adjustable Floor Stand for Displays up to 22 lbs- Black

ADD-MSADFSB

INSTRUCTION - MANUAL

CONTENTS:

CP-DMCFCVS156

CP-UX700156S

CP-SMBCVS156

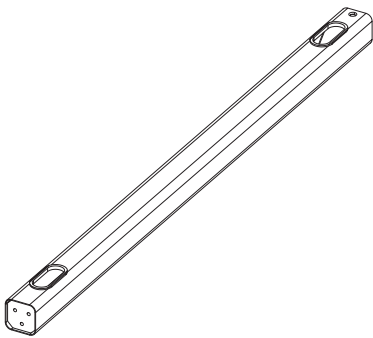

A (x1)

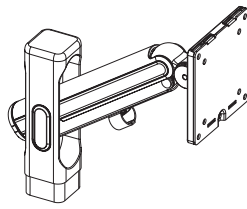

B (x1)

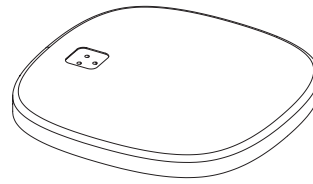

C (x1)



M-A (x4)
M4x12



M-B (x4)
D5



D (x2)
M5x10

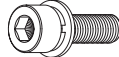

E (x3)
M6x20



F (x1)
3mm



G (x1)
5mm (Long Type)

INSTALLATION:

1. Assembling Base to Body

VESA Compatible
75x75 - 100x100

35"
MAX

2-10kg
(4.4-22lbs)
RATED



Note: Keep the cable holes to the side facing up as shown

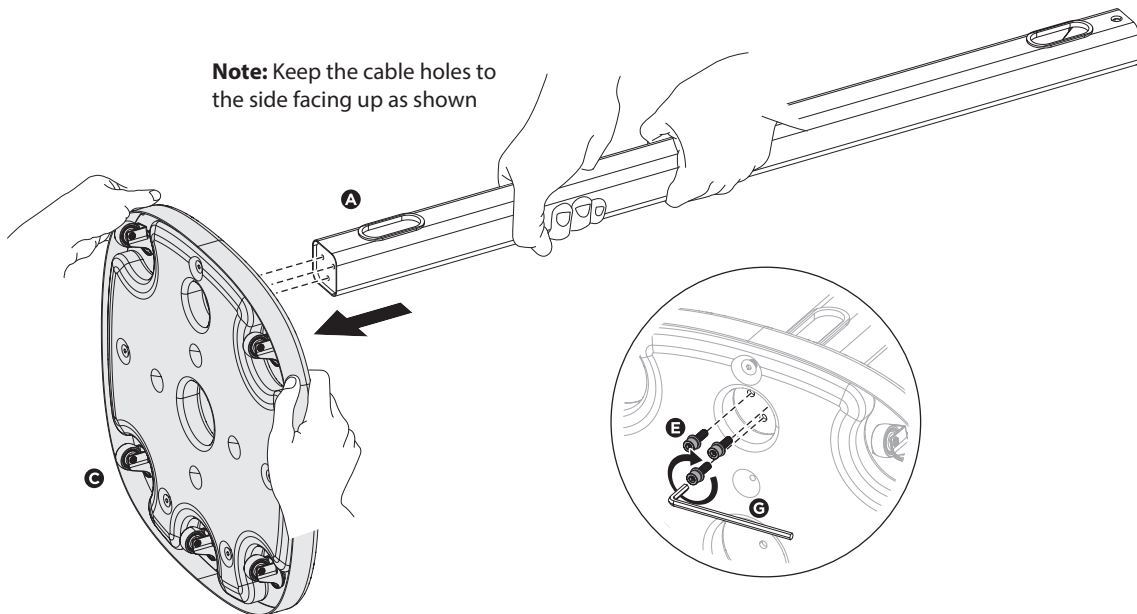

1A - Align the mounting holes at the bottom of the floor stand body (A) to the weighted base (C) mounting holes as illustrated above. Rotate in three screws (E) from below the base using provided tool (G) until securely tightened.

2. Removing VESA Plate Component from Arm

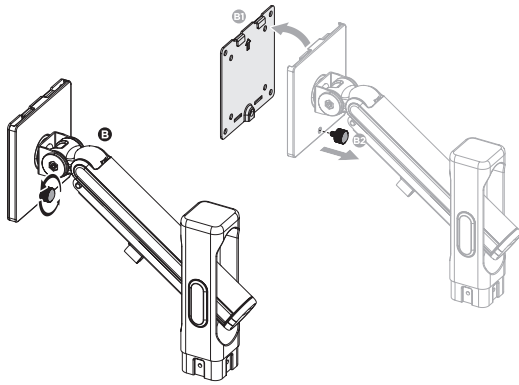

2A- Identify the knob on the VESA plate joint as shown. Rotate counter clockwise to loosen. Then lift up and out the front part of the VESA plate to remove and separate from the arm.

3. Attaching Articulating Arm to Body

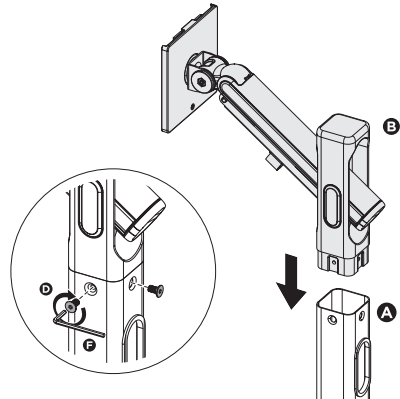

3A- Take the articulating arm component (B) and slide it down on the body (A) as shown. Rotate in the two screws (D) using provided tool (F) until securely tightened.

4. Attaching VESA Plate to Monitor

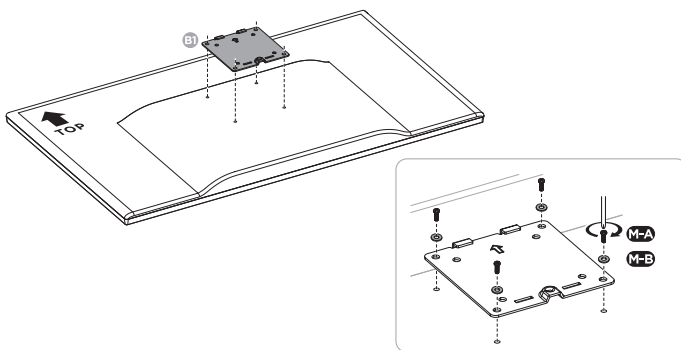

4A- Take the now removed front VESA plate component and align VESA mounting holes to that of your device (not included). Rotate in four screws (M-A) and four washers (M-B) from behind at the mounting holes using screwdriver tool (not included) until securely tightened.

5. Attaching VESA Plate & Device Back to Arm

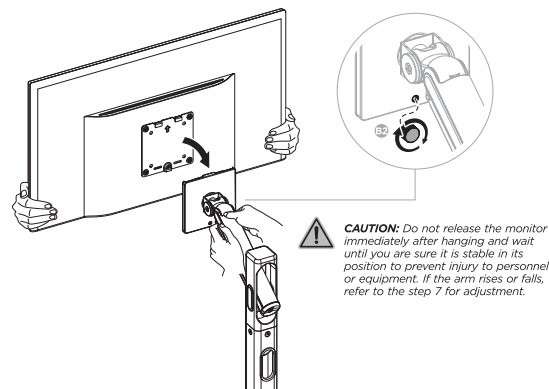

CAUTION: Do not release the monitor immediately after hanging and wait until you are sure it is stable in its position to prevent injury to personnel or equipment. If the arm rises or falls, refer to the step 7 for adjustment.

5A- Take the now attached device and front VESA plate component and slide downward back to the back VESA plate counterpart component on the articulating arm (B) to attach. Rotate the knob to tighten and secure as shown.

6. Cable Routing

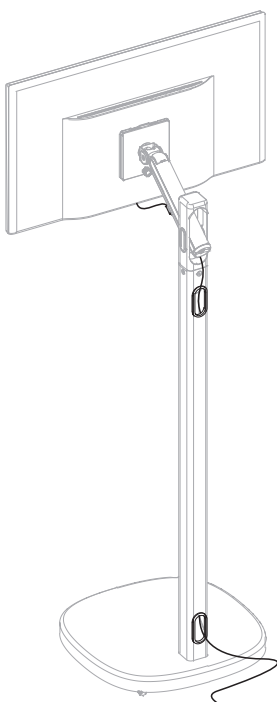

6A- Route your device cable (not included) through the body (A) and out the designed openings as shown. Take one end and attach to your device and the other end to the outlet or power supply. There are clips below the arm you can hang the cable onto at that area.

7. Height Adjustability & Tilt Adjustability

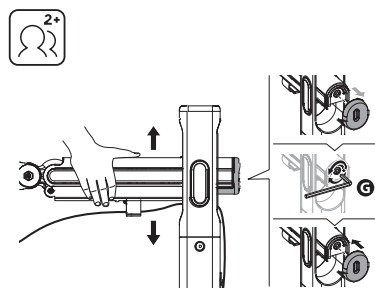

Before adjusting the spring tension and during the adjustment process, position and hold the arm horizontally as shown. Use the supplied Allen Key for adjustment. Ask for assistance should you require it

7A- When adjusting the arm height, first remove the end cap at the back side as shown. Take the provided tool (G) to loosen the resistance. Adjust the arm up or down to desired location. Use the same tool to tighten and then place the end cap back on to set the arm.

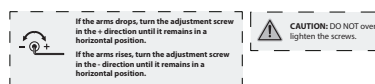

CAUTION: DO NOT over tighten the screws.

7B- When adjusting the device angle tilt, first loosen the VESA joint as shown to the left with provided tool (G) first. Use your hands and tilt forward or back to your ideal preference. You can also rotate it for portrait or landscape orientations. Make sure to unplug all wires first. Retighten the joint when all adjustments are finished to lock it in.



Note: If the display does not slop at your desired position, adjust the screws using the tools as shown.